

ELEXON BUSINESS SEPARATION PLAN



**MHHS
PROGRAMME**

Industry-led, Elexon facilitated

Ensuring the MHHS Programme acts independently
and serves all industry participants equally.

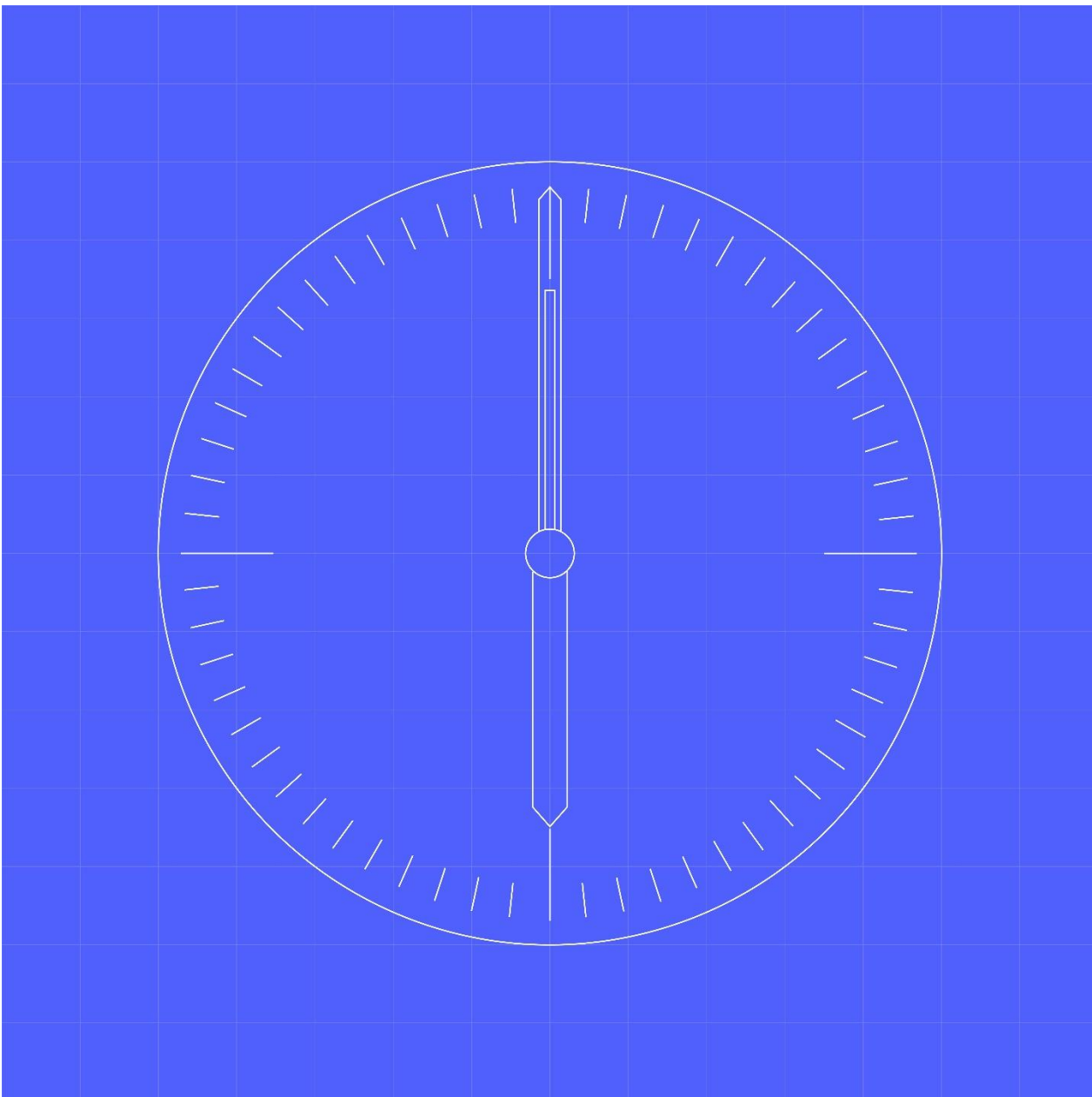

Document owner

[Angela LoveHelen
Tipton](#)

Document number

MHHS-DEL031

Version

1.12.0

Status:

Approved

Date

**~~11 May 2022~~ 04 April
2023**

Contents

Contents	1
1. Purpose	4
2. Industry-led	4
3. Scope	4
4. Subject to change	4
5. Summary of expected outcomes	5
6. Elexon as MHHS Implementation Manager	7
7. Simplified summary of MHHS governance	9
8. Potential conflict of interest	11
9. Business separation obligations	11
10. Organisational separation	12
11. Cultural separation	<u>1948</u>
12. Physical separation solution	<u>2120</u>
13. Implementation and maintenance	<u>2324</u>
Appendix 1	<u>2422</u>
Appendix 2	<u>2422</u>
Appendix 3	<u>2523</u>
Appendix 4	<u>2624</u>
Appendix 5	<u>2725</u>
Appendix 6	<u>2826</u>
Appendix 7	<u>2826</u>
Appendix 8	<u>2927</u>
Appendix 9	<u>2927</u>
Appendix 10	<u>3028</u>
Appendix 11	<u>3028</u>

Versions

Date	Author	Version	Change Detail
19/07/2021	Warren Fulton	0.1	Draft version for review
29/07/2021	Warren Fulton	0.2	Updated with comments from A. Love, A. Margan, C. Hyde, C. Harden, C. Welby, E. Sheppard, E. Ridgeway, I. Smith, M. Bygraves
30/07/2021	Warren Fulton	0.3	Updated with comments from C. Welby
31/07/2021	Warren Fulton	0.4	Updated with comments from A. Love, C. Harden.
03/08/2021	Warren Fulton	0.5	Updated with comments from M. Bygraves
03/08/2021	Warren Fulton	0.6	Updated with comments from M. Bygraves
04/08/2021	Warren Fulton	0.7	Updated with comments from M. Gibbons
13/08/2021	Warren Fulton	0.8	Updated with comments from Elexon Board meeting, M. Bygraves, A. Love.
17/08/2021	Warren Fulton	0.9	Updated with comments from M. Bygraves, A. Love, C. Welby
02/09/2021	Warren Fulton	0.10	Updated with comments from Ofgem – A. Stacey, A. MacFaul
08/09/2021	Warren Fulton	0.11	Updated with comments from C. Welby, A. Love
09/09/2021	Warren Fulton	0.12	Updated with comments from M. Bygraves
26/09/2021	Warren Fulton	0.13	Updated with comments from Ofgem – A. MacFaul
27/09/2021	Warren Fulton	0.14	Updated with comments from M. Gibbons
28/09/2021	Warren Fulton	0.15	Updated with comments from Ofgem – A. MacFaul
07/10/2021	Warren Fulton	0.16	Updated with comments from Elexon Board meeting
01/11/2021	Warren Fulton	0.17	Accepted all amendments in v0.16 and marked up with comments from Ofgem – A. MacFaul
10/11/2021	Warren Fulton	0.18	Accepted all amendments in v0.17 and marked up with comments from Ofgem – A. MacFaul
10/11/2021	Warren Fulton	1.0	Accepted all amendments in v0.18 and received approval from A. MacFaul to rename to V1.0 and submit for Ofgem approval
11/05/2022	Kat Hamblin	1.1	Updated brand elements
23/01/2022	Nicholas Brown	1.2	Updated with comments from H. Tipton
15/03/2023	Helen Tipton	1.21	Under review following comments from Ofgem – A. MacFaul
04/04/2023	Nicholas Brown	2.0	Amendments from Ofgem incorporated and final amendments agreed

Reviewers

Reviewer	Version	Role
Angela Love	0.16	Director of Future Markets and Engagement
Chris Welby	0.16	MHHS SRO (Interim)
Chris Harden	0.16	MHHS Programme manager
Charles Hyde	0.1	MHHS Procurement lead
Caroline Jankowska	0.1	Head of Elexon Human Resources
Emma Sheppard	0.1	MHHS PMO manager
Ian Smith	0.1	MHHS Design manager
Mark Bygraves	0.16	Elexon CEO
Andrew Margan	0.1	Senior Programme Office Manager
Eden Ridgeway	0.15	Legal counsel
Nicholas Brown	0.15	General counsel
Michael Gibbons	0.15	Elexon Chairperson
Elexon Board	0.15	
Ofgem	0.18	Rachel Clark, Anna Stacey, Andrew MacFaul

References

Document	Publisher	Published	Link
Decision Document – Implementation Arrangements for Market-Wide Half-Hourly Settlement	Ofgem	11 Aug 2021	Ofgem website
BSC, Section C	Ofgem	30 Sep 2021	Elexon website
MHHS Governance Framework	Ofgem	1 Nov 2021	Ofgem website
Consultation document – Implementation Arrangements for Market-Wide Half-Hourly Settlement	Ofgem	23 April 2021	Ofgem website

Terminology

Term	Description
DA	Design Authority
IM	Implementation Manager
IPA	Independent Assurance Provider
LDP	Lead Delivery Partner
PMO	Programme Management Office
PPC	Programme Party Co-ordinator
Project Helix	Elexon Central Systems internal programme for MHHS
SRO	Senior Responsible Owner
SI	Systems Integrator

1. Purpose

The purpose of the Elexon Business Separation Plan is to define and implement a solution that enables Elexon to successfully deliver the Market-wide Half-Hourly Settlement (MHHS) Programme whilst acting autonomously and serving all industry participants fairly and equally.

As per the MHHS Governance Framework published by Ofgem in November 2021, Elexon is required to develop, obtain Ofgem's approval of, and comply with a "Business Separation Plan". This document is the proposed Business Separation Plan, and an implementation plan will be published when the Business Separation Plan is approved.

Once approved, this document will be published to the Elexon website and the MHHS Programme website.

2. Industry-led

The MHHS Programme is an industry first, in that Ofgem has confirmed that Elexon should facilitate an industry-led solution by operating as the MHHS Implementation Manager (IM) (as explained in section 6 of this document).

To enable an industry-led solution and implementation, all Programme decisions which are 'below threshold' will be taken by the Senior Responsible Owner (SRO) in the Programme Steering Group (PSG) or by groups to which the SRO has delegated certain decisions, as explained in section 7 and 10.1.

The MHHS Programme presents the opportunity to develop new ways of working and to create a 'blueprint' for future large change programmes within the industry. Elexon believes that it is creating a unique culture for the MHHS Programme by giving the Programme its own identity and physical presence; and recruiting the best skills and companies to resource the Programme, whilst also seconding Elexon and industry stakeholders to guide the solution design.

3. Scope

Elexon recognises the importance, and is committed to, defining and implementing a lasting solution that enables Elexon to successfully deliver the MHHS Programme whilst serving all industry participants fairly and equally. The scope of the Business Separation Plan is to define a solution that enables the Programme to act autonomously and satisfy the Business Separation obligations (described in section 9) as defined in the MHHS Governance Framework. The scope will also ensure Elexon is not restricted in its ability to successfully deliver the MHHS Programme.

Once implemented, the ownership of the Business Separation Plan and its ongoing monitoring and maintenance will reside with the Elexon MHHS Programme Executive [Sponsor Representative](#), and ultimately the Elexon Board. The Elexon Board is ultimately accountable for Elexon's activities as the MHHS IM and as a MHHS Programme participant/central services provider (referred to as Project Helix) and, importantly, managing the potential conflict of interest risk between the two. To clarify, Elexon has named the Central Systems internal programme for MHHS, "Project Helix".

4. Subject to change

This Business Separation Plan is based on two documents, namely (1) the BSC, and (2) the MHHS Governance Framework. Elexon made submissions to Ofgem during the consultation about the MHHS IM roles, responsibilities, obligations and governance requirements, which were taken on board in all material respects.

BSC Modification P423 was unanimously recommended by the BSC panel on 16 September 2021 and was approved by the Authority on 30 September 2021.

The Business Separation Plan is subject to approval by the Elexon Board and Ofgem.

5. Summary of expected outcomes

The table below captures the expected outcomes of the Business Separation Plan, defines how success will be measured and documents the associated solutions that are being, or have been, implemented.

Expected outcome	What are we aiming for (success criteria)	What is the solution (deliverables / controls)
Clarification of obligations and responsibilities		
Exlexon understands the MHHS IM roles and responsibilities	No instances of confusion of accountability or responsibility.	<ul style="list-style-type: none"> MHHS IM roles and responsibilities confirmed (as outlined in section 6) MHHS Programme governance confirmed (as outlined in section 7) Ofgem/Elexon responsibilities confirmed (as outlined in section 10.1, 10.2)
Exlexon is able to fulfil its MHHS IM obligations without unreasonable constraints.	No instances of restrictions on Exlexon to perform IM responsibilities.	<ul style="list-style-type: none"> Exlexon Board control and access to information confirmed (as outlined in section 10.6)
Exlexon 'subject matter expert' participation in the MHHS Programme is not adversely affected by Business Separation obligations.	Minimal instances where Exlexon personnel do not want to join, or support the MHHS Programme, due to separation restrictions / obligations.	<ul style="list-style-type: none"> Exlexon MHHS HR principles defined (as outlined in section 11.3) Exlexon engagement guidance defined (as outlined in section 11.5) Employee communications on separation approach (as outlined in section 11.4)
Operational separation		
MHHS Programme decision makers do not give Exlexon Central Systems preferential treatment.	No instances of programme decisions that were made to unduly benefit Exlexon Central Systems, as confirmed by the IPA.	<ul style="list-style-type: none"> Executive decision-making separated (as outlined in section 10.3) Exlexon Board agenda separated (as outlined in section 10.4) SRO independence (as outlined in section 10.5)
MHHS Programme does not give Exlexon Central Systems preferential access to information.	No instances of Exlexon Central Systems benefitting from undue access to information, as confirmed by the IPA.	<ul style="list-style-type: none"> Conflict of interest awareness training (as outlined in section 11.1) Programme specific data directory (as outlined in section 12.5) Exlexon engagement guidance defined (as outlined in section 11.5) Employee communications on separation approach (as outlined in section 11.4)
Save in circumstances beyond Exlexon's control,	No undue programme delays due to	<ul style="list-style-type: none"> Outsourcing majority of programme roles (as outlined in section 10.7)

the MHHS Programme is not affected by Elexon resource capability.

personnel secondment or recruitment, procuring service providers, IT systems, facilities, HR or finance.

- Recruited external resources (as outlined in section 10.8)
- Roadmap of support services requirements and monitoring performance (as outlined in section 10.9)
- Professional services support arrangements confirmed (as outlined in section 10.10)
- Seconding Elexon SME's and recruiting fixed-term employees (as outlined in section 11.2)

Cultural separation

MHHS IM resources see themselves first and foremost as part of the industry-wide MHHS Programme.

No instances of bias towards Elexon, as confirmed by the IPA.

- Conflict of interest awareness training (as outlined in section 11.1)
- Outsourcing majority of programme roles (as outlined in section 10.7)
- Recruited external resources (as outlined in section 10.8)
- Seconding Elexon SME's and recruiting fixed-term employees (as outlined in section 11.2)
- Elexon MHHS HR principles defined (as outlined in section 11.3)
- Employee communications on separation approach (as outlined in section 11.4)
- Elexon engagement guidance defined (as outlined in section 11.5)

Physical separation

MHHS Programme is recognised as an industry-led programme with its own identity.

No confusion on the part of programme participants as to who the Programme team are.

- MHHS Programme brand developed (as outlined in section 12.1)
- MHHS Programme email addresses live (as outlined in section 12.2)
- MHHS Programme office space acquired (as outlined in section 12.3)
- MHHS Programme website (as outlined in section 12.4)
- MHHS Programme specific data directory (as outlined in section 12.5)

6. Elexon as MHHS Implementation Manager

6.1 Summary of MHHS: IM responsibilities

BSC Section C.12 (as modified by P423 with effect from 7 October 2021) explains that the MHHS Implementation Manager is a grouping of five distinct roles, each with its own responsibilities, supported by a set of responsibilities that have been classified as “General”.

The diagram below illustrates the various IM roles and the ‘General responsibilities’, and provides a reference to the relevant section in the BSC where the role and its responsibilities are defined. Elexon is referred to as the “BSCCo” in the BSC, and the diagram follows the same standard.

Elexon, in response to industry feedback and in consultation with Ofgem, has decided to outsource the PMO, PPC and SI roles via a procurement to a Lead Delivery Partner (LDP).

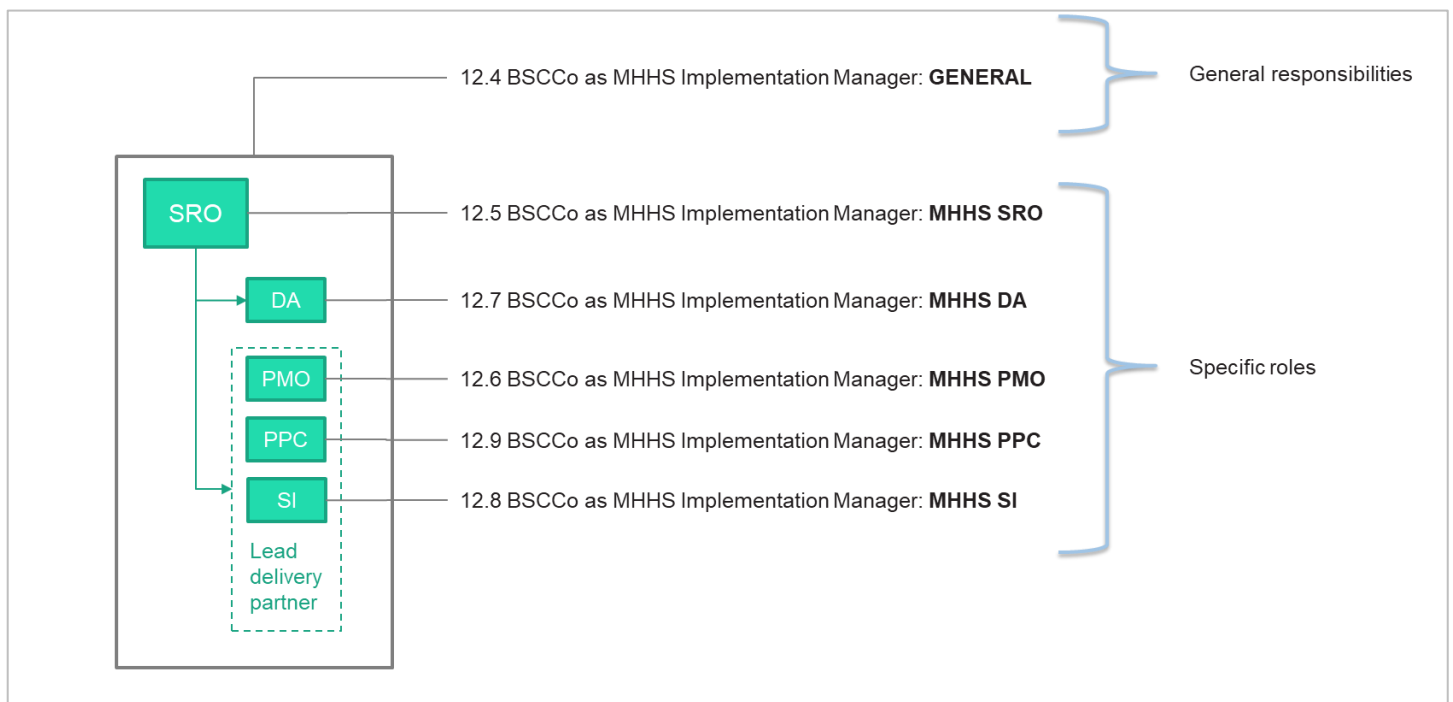

The numbering in this diagram (e.g. 12.4) refers to the BSC Section C.

6.2 Explanation of MHHS: IM responsibilities

The following table is a summary of the IM responsibilities as described by Ofgem.

Reference: BSC, Section 12, as modified with effect from 7 October 2021.

Responsibility	Description
IM: GENERAL	<p>The BSCCo shall: [abridged]</p> <ul style="list-style-type: none"> “ensure that it maintains the service providers and personnel (with the necessary qualifications and experience), IT Systems and facilities necessary to enable it to perform its role as MHHS Implementation Manager” “ensure that the service providers, personnel, IT Systems and facilities it uses to perform its role as MHHS Implementation Manager are sufficiently separated from those it uses as an MHHS Participant, as further described and set out in the MHHS Governance Framework and a business separation plan” “always remain responsible under this Code for the performance of the MHHS Implementation Manager roles” “The [BSCCo] Board shall ensure that BSCCo complies with [BSC C12.4.3]” “without limitation, the [BSCCo] Board shall maintain appropriate delegations to specified executive members and the MHHS SRO (and, by extension, the rest of the MHHS Implementation Manager function).” “ensure that, where it does need to share any MHHS Implementation Manager information with its executive or board members to facilitate the performance of their oversight responsibilities, such information is anonymised between MHHS Participants.” “ensure that the Authority and the MHHS Independent Assurance Provider are informed that the information has been shared and provided with a record of any decisions in relation to it.” “subject to such oversight, and notwithstanding programme information available to MHHS Participants, information available to the MHHS Implementation Manager roles must not be shared with the rest of BSCCo (including the Board).” “shall prepare and make available to the Panel and to the MHHS Programme Steering Group regular reports in respect of BSCCo’s activities as MHHS Implementation Manager, and the costs incurred as the MHHS Implementation Manager.”
IM: SRO (Senior Responsible Owner)	<p>“The MHHS SRO shall be responsible for delivery of MHHS Implementation in accordance with the MHHS Implementation Timetable, and accountable for ensuring that MHHS Implementation delivers the MHHS Target Operating Model and achieves the other outcomes specified by the Authority as part of the market wide half-hourly settlement Significant Code Review. The MHHS SRO shall perform its role in accordance with the design and implementation baselines determined by the Authority, as they are amended from time to time in accordance with the MHHS Governance Framework.”</p>
IM: DA	

(Design Authority)	“The MHHS DA shall be responsible for securing the robust and stable design of the business processes and IT Systems via which market-wide, half-hourly Settlement is to be provided, including the existing and new IT Systems of BSCCo and any other new central IT System and the interface of those IT Systems with those of other MHHS Participants (but excluding the IT Systems of such other MHHS Participants).”
IM: PMO (Programme Management Office)	“The MHHS PMO shall be responsible for providing full and effective programme management to support MHHS Implementation.”
IM: PPC (Programme Party Coordinator)	“The MHHS PPC shall be responsible for full and effective co-ordination of MHHS Participants in relation to MHHS Implementation.”
IM: SI (Systems Integrator)	“The MHHS SI shall be responsible for securing the robust and stable integration of the business processes and IT Systems to be used by MHHS Participants for the purposes of market-wide, half-hourly Settlement.”

7. Simplified summary of MHHS governance

The diagram below provides a simplified summary of the MHHS Programme governance structure for illustrative purposes.

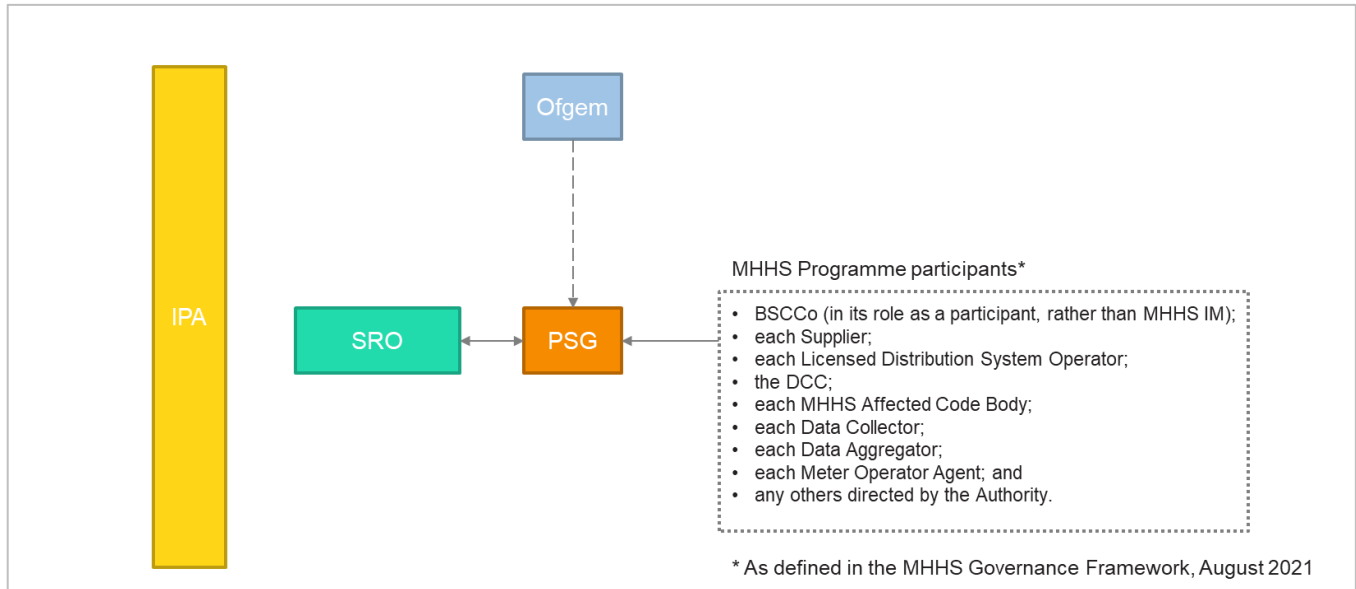

The subsequent sections provide a summary of the role and responsibilities of the PSG, IPA, SRO and Ofgem as the Sponsor, as per the MHHS Governance Framework and BSC.

7.1 Programme Steering Group (PSG)

Comprised of industry representatives, “the PSG is the key programme decision-making group. The SRO will make decisions in the PSG, informed by the PSG and seeking consensus among PSG members. Where the SRO is unable to achieve consensus they will articulate the reason for their decision, and the dissenting voices, and seek the views of the Independent Assurance Provider as to whether the matter meets the thresholds for reference to Ofgem.”
(Reference MHHS Governance Framework)

7.2 Independent Assurance Provider (IPA)

“The IPA will monitor for potential conflicts of interest in Elexon's decision making, and also monitor the extent to which the interests of existing and future consumers are being taken into account.

The focus of the IPA will be to provide evidence throughout the implementation of MHHS to the SRO, the PMO, the Programme Steering Group and ultimately to Ofgem, to support key decision points, milestones and quality gates in the programme and to assure that the information the programme is being provided by the relevant organisations is accurate, timely and complete, although the IPA will not be assuring each individual MHHS Participant as a matter of course.

The IPA may also be called on from time to time, to provide independent advice on matters arising which could impact on the delivery of the Programme. Whilst Ofgem will contract with the assurance provider, the SRO will be responsible for contract management and shall instruct the assurance provider in accordance with reasonable requests for assurance reports from the Programme Steering Group.” (Reference MHHS Governance Framework)

“Subject to compliance with the MHHS Governance Framework the [Elexon] Board shall be entitled to meet with the MHHS Independent Assurance Provider and to ask the MHHS Independent Assurance Provider to consider and report on any matter in relation to performance of the MHHS Implementation Manager roles (in which case such reports shall be made available to all MHHS Participants, unless the Authority directs otherwise).” (Reference BSC)

7.3 Senior Responsible Owner (SRO)

“The SRO has responsibility and accountability for delivering MHHS according to the design and implementation plan baselines set by Ofgem. The SRO will be obliged to operate programme governance as described here. The SRO will chair the Programme Steering Group and will formally take Steering Group decisions. The SRO should aim for consensus wherever possible and seek to take into account the interests of all programme parties and consumers. The SRO is accountable for keeping MHHS implementation to plan. The SRO will need to ensure that decisions are taken in a timely way, whilst ensuring that appropriate consultation of all programme parties is carried out at all stages. Where the SRO is unable to make a decision because it meets the threshold set out for Ofgem intervention, they will provide a recommendation to Ofgem for consideration.” (Reference MHHS Governance Framework)

“The MHHS SRO shall perform its role in accordance with the design and implementation baselines determined by the Authority, as they are amended from time to time in accordance with the MHHS Governance Framework.” (Reference BSC)

7.4 Ofgem as sponsor

“Ofgem set the design and implementation plan baselines in the Decision Document published in April 2021. Ofgem retains overall accountability for achieving the outcomes set out in the Decision Document published alongside the Full Business Case. The thresholds for decisions that will need to be approved by Ofgem are set out below [in Appendix 4], which includes when decisions have particular impacts on design, plan baselines, costs or consumers. In addition, Ofgem has a role ensuring that parties are treated fairly within the programme and that any conflicts of interest between Elexon's roles in the programme are effectively managed.” (Reference MHHS Governance Framework)

8. Potential conflict of interest

As part of Ofgem consulting on the implementation and governance arrangements for the introduction of MHHS, certain conflict of interest risks were raised by consultation respondents, namely:

- Possible conflict of interest in Exelon being appointed as Senior Responsible Owner (SRO), Programme Management Office (PMO) and Design Authority (DA), as well as having a central role in building the systems needed to deliver MHHS.
- Possible Exelon bias towards BSC parties, given the perception that Exelon's default position will be to favour the interests of BSC parties, whom they essentially view as their customers.
- There should be a visible and tangible separation of Exelon's programme management function from other parts of Exelon's work.

Simply put, concerns were expressed that Exelon is at risk of affecting the MHHS Programme due to:

- Conflict: Exelon in its role as IM/SRO giving Exelon central systems development, or other BSC parties, preference in terms of decision-making and access to information.
- Capability: Limiting programme performance based on Exelon resource capacity / capability.

Appendix 1 provides a summary of industry responses on potential conflicts.

Appendix 2 provides examples of potential conflict of interest provided by Ofgem.

9. Business separation obligations

To mitigate the potential conflict of interest risks, Ofgem has obligated Exelon to adhere to business separation obligations as defined in the BSC Section C.12.4.3 and the MHHS Governance Framework. A copy of the obligations can be viewed in Appendix 10.

A summary of the obligations has been provided below.

- Exelon's role as MHHS Implementation Manager is to be kept separate from its role as an MHHS participant.
- Exelon shall develop, obtain Ofgem's approval of, and comply with a business separation plan which requires explicit, physical, organisation and cultural separation, including:
 - Physical – separate office spaces, websites, and email addresses
 - Organisation – [with the exception of the Exelon CEO](#), the people who are taking operational and management decisions in relation to the MHHS IM roles must not be the same people who take decisions in relation to the MHHS participant role. [The Exelon CEO does not sit on either the MHHS Programme Steering Group \(PSG\) or the Helix Programme Steering group. The role of the CEO, and the constraints around that role, are described in sections 10.3 and 10.4 below.](#) Reporting from the MHHS IM units to the Exelon executive and board should be in accordance with BSC Section C 12.4.3
 - Cultural – this may be achieved through the appointment of external service providers for particular roles, but can also be achieved through staff training on awareness of separate functions.

The subsequent sections of this Business Separation Plan address these obligations in the following order:

- Organisational separation (section 10)
- Cultural separation (section 11)
- Physical separation (section 12)

10. Organisational separation

This section explains Elexon's solution to the Organisational separation obligations as per the Business Separation obligations defined in the MHHS Governance Framework.

10.1 Ofgem / Elexon (IM) – Clarification of responsibilities

Ofgem has confirmed that Elexon, acting as the IM, will be responsible for the timely delivery of the MHHS Implementation. Ofgem will retain power to step in, if needed.

Ofgem has published Programme baselines (costs, benefits, TOM and timelines) and thresholds for decisions that impact those baselines. Decisions that are deemed 'above threshold' will be referred to Ofgem, and Ofgem will be accountable for their decisions. All Programme decisions which are 'below threshold' will be taken by the SRO in the Programme Steering Group (PSG) or by groups to which the SRO has delegated certain decisions.

Elexon as the IM will be held accountable to ensure the Programme is appropriately resourced and supported to deliver according to these baselines, which Ofgem may change from time to time.

Appendix 3 provides an accountability matrix, illustrating MHHS accountabilities.

Appendix 4 provides the Ofgem decision-making thresholds.

10.2 Ownership of MHHS IM responsibilities within Elexon

The Elexon Board's role in the MHHS IM has been clarified in the BSC. A copy of the text can be viewed in Appendix 11.

A summary of the text has been listed below:

- Without limitation, the Elexon Board shall maintain appropriate delegations to specified executive members and the MHHS SRO (and, by extension, the rest of the MHHS Implementation Manager function).
- Where MHHS IM information is to be shared with Elexon executive or board members to facilitate the performance of their oversight responsibilities, such information is anonymised between MHHS participants.
- Where such information has been shared, Ofgem and the IPA will be informed of the information shared and any decisions in relation to it.
- Excluding the information required for oversight, and notwithstanding Programme information available to MHHS participants, information available to the MHHS IM roles must not be shared with the rest of BSCCo, including the Board.
- Subject to compliance with the MHHS Governance Framework, the Board shall be entitled to meet with the MHHS IPA and to ask the MHHS IPA to consider and report on any matter in relation to performance of the MHHS IM roles (in which case such reports shall be made available to all MHHS Participants, unless the Authority directs otherwise).

The diagram below illustrates how the MHHS IM responsibilities have been allocated within Elexon to ensure the people who are taking operational and management decisions in relation to the MHHS IM roles are not the same people who take decisions in relation to the MHHS participant role.

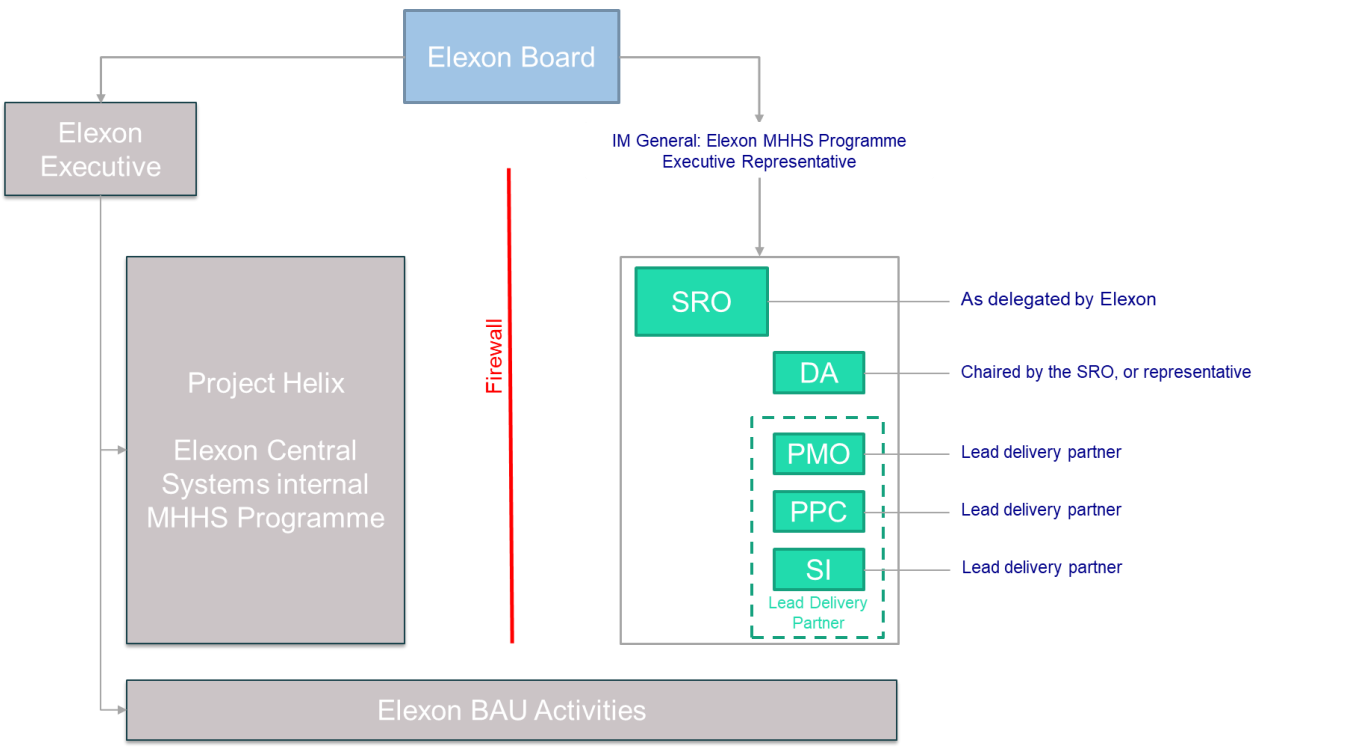
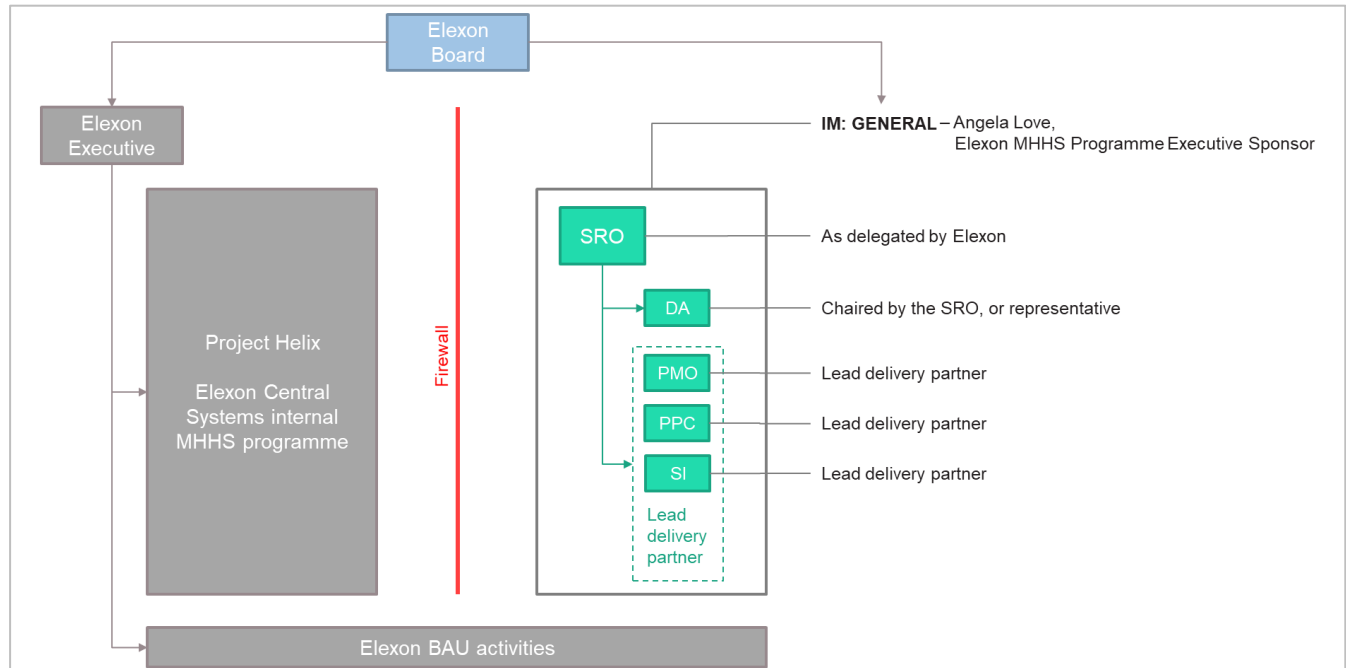

Responsibility	Person / party
IM: GENERAL	Angela Love Chief Executive Officer
IM: GENERAL	Programme Executive Representative
IM: SRO	As delegated by Elexon
IM: DA	Chaired by the SRO or representative

IM: PMO	Lead delivery partner
IM: PPC	Lead delivery partner
IM: SI	Lead delivery partner

10.3 IM: General – Exelon MHHS Programme Executive Representative

In accordance with the Exelon Board’s Schedule of Reserved Matters, the Board will not be any more, or any less, involved in the decision making of the ‘IM: General responsibilities’ than they would be in relation to other BSCCo activities.

In keeping with normal corporate governance and with the Company’s division of responsibilities between the Chair and the CEO, the Board has delegated executive management of the MHHS Programme to the CEO. With a view to enabling the separation of decision-making responsibility within the executive management of Exelon, the CEO has appointed an Exelon MHHS Programme Representative who is responsible for the day-to-day management of the ‘IM: General responsibilities’ role.

The Exelon Board has assigned executive leadership of the role to the Exelon MHHS Programme Executive Representative, and has delegated the executive management of the ‘IM: General responsibilities’ to this role. The Exelon MHHS Programme Executive Representative will ensure the Exelon Board is kept abreast of pertinent matters and consulted on key decisions.

~~In accordance with the Exelon Board’s Schedule of Reserved Matters, the Board will not be any more, or any less, involved in the decision making of the ‘IM: General responsibilities’ than they would be in relation to other BSCCo activities.~~

~~Angela Love~~Exelon’s MHHS Programme Executive Representative is not a member of the Board, is not a decision-maker in Project Helix and ~~her role as the Director of Future Markets and Engagement does not place her in a position of conflict with her role as the Exelon, The MHHS Programme Executive Sponsor.~~ Angela Representative does not receive any information in relation to Project Helix, other than high level information or information that is otherwise available to the MHHS Programme, and does not take part in programme or decision making meetings in relation to Project Helix. Whilst some of the Exelon Design Authority do support Project Helix, none of these resources report directly to ~~Angela~~the MHHS Programme Executive Representative and neither are they specifically directed by ~~Angela~~the MHHS Programme Executive Representative.

Besides the Exelon MHHS Programme Executive ~~Sponsor~~Representative, only Exelon Board directors, including the CEO, and the company ~~secretary~~secretariat, rather than other Exelon Executive team members, will have access to the information and decisions involved in managing the ‘IM: General’ responsibilities. A reminder that any information shared with the Exelon executives or Board must be in accordance with BSC 12.4.3 (view section 10.2 and 6.2).

The Exelon MHHS Programme remains accountable to the CEO who is accountable, in turn, to the Board for the performance of the IM: General responsibilities role.

10.4 IM: General – Exelon Board

The Exelon Board is required to maintain oversight over the ‘IM: General’ responsibilities because the responsibilities relate to monitoring and managing the performance of the MHHS IM roles, procurement, ensuring accurate accounting, maintaining separation and ensuring the Programme is appropriately resourced and the resources are performing optimally. The oversight of these responsibilities cannot be delegated to an external body as they relate to Exelon’s corporate and reputational obligations.

The MHHS Programme IM roles are operating in a fast moving environment and, as a result, effective and efficient delivery of the MHHS Programme is likely to require regular management interventions. Recognising that the Exelon Board is largely comprised of non-executive directors who only meet at periodic intervals, the Board has delegated

executive oversight of the MHHS Programme to the CEO and day-to-day management to the Exelon MHHS Programme Representative.

The CEO shall be involved in the oversight of the Programme on a regular basis, outside Board (or Board Committee) meetings. This involvement will support effective and efficient Programme delivery by enabling the Programme to utilise the CEO's senior level skills and experience. In addition to being a Board member, the role of the CEO is to ensure that the MHHS Programme is operating effectively, to liaise with senior stakeholders, to ensure the implementation of decisions by the Exelon Board (or Board committee), to operationalise the Programme support and assistance provided by the Board's (or Board committee's), and to act as a conduit between the Board (or Board committee) and the MHHS IM roles. In order to maintain separation of decision making, the CEO shall not be involved in MHHS Programme delivery decisions other than, to the extent permitted by this Separation Agreement, as part of the Exelon Board.

It is acknowledged that the Exelon Board will also be required to maintain oversight of Exelon's performance as a Programme participant. To ensure the boundary between the two roles does not become blurred, and to mitigate the potential risk of conflict, the Exelon Board will allocate a separate agenda item at itsput in place arrangements to ensure that Board ~~meetings for level items~~ relating to the oversight of the 'IM: General' responsibilities will be considered separately from other matters, where only information and decisions relevant to the 'IM: General' responsibilities will be tabled and taken. ~~To aid transparency, all decisions taken in relation to the 'IM: General' responsibilities will be shared with the IPA after every Board meeting.~~

As a reminder, these will be decisions that relate to:

- Maintaining the service providers, personnel, IT Systems and facilities necessary for the Programme.
- Monitoring and managing the performance of the MHHS IM roles.
- Ensuring that MHHS IM resources and infrastructure are sufficiently separated from those used as a participant.
- Ensuring an account is kept of costs, expenses and liabilities incurred in the role of MHHS IM.

To aid transparency:

- the Board will be provided with regular reporting which enable it to exercise its oversight role, including monitoring compliance with this Business Separation Plan by the CEO and Exelon MHHS Programme Representative
- all decisions based on MHHS IM information will be shared with the IPA after every Board meeting. MHHS IM information means information relating to the MHHS Programme that is (i) not available to all Programme participants; and/or (ii) does not relate to the management of MHHS IM resources.

Note that MHHS Programme delivery decisions, such as priorities, schedule, risks and issue mitigation are taken by the SRO in the PSG. The Exelon Board can influence these decisions by means of Exelon's attendance at the PSG as a Programme participant. The Exelon Board, executives or employees may not influence these decisions outside of the PSG, as such activity will present a conflict of interest. Should the Exelon Board disagree with a decision taken in the PSG, it may engage the IPA to provide an independent assessment and recommendation.

10.5 IM: SRO independence

The MHHS SRO ~~will may have no Exelon other responsibilities outside, including being a member of the Exelon Executive Team, and may manage Exelon employees other than those involved in the MHHS SRO responsibilities. Programme provided that:~~

- The MHHS SRO will have no decision making authority within the Exelon Central Systems programme (Project Helix) and will not manage any Exelon employees other than those working on the MHHS Programme. The MHHS SRO will be performance managed by the Exelon MHHS Programme Executive Sponsor exclusively.);
- Exelon must ensure that the MHHS SRO devotes sufficient time to MHHS Programme;

- [The MHHS SRO will be performance managed either by the Elexon CEO or, if the MHHS SRO is not a member of the Elexon Executive team, by the Elexon MHHS Programme Executive Representative.](#)

10.6 IM: General – Access to information and decision-making authority

The table below provides an indication of the types of information that the Elexon ~~MHHS Programme Executive Sponsor~~ requires to perform the 'IM: General' responsibilities, and the types of decisions that are expected to be taken. Subject to the delegations explained in section 10.3 and 10.4, the Elexon MHHS Programme Executive ~~Sponsor~~[Representative](#) can share pertinent information ~~and consult on key decisions~~ with Elexon Board directors. ~~Decisions will be taken in accordance with Elexon's delegated authorities.~~

Responsibility	Information required	Decisions to be taken
Maintaining the SERVICE PROVIDERS necessary for the Programme.	<ul style="list-style-type: none"> • 90 day roadmap of service provider requirements • Status report on fulfilment of service provider requirements • Procurement process compliance • Legal review of contracts • Risks / issues regarding contract disputes / changes • Issues / risks raised by the PSG, IPA, Programme participants regarding service providers 	<ul style="list-style-type: none"> • Start / terminate procurement processes • Ratify / reject procurement decisions • Sign procurement contracts • Ratify contract changes / cancellations • Intervention for non-compliance with procurement policy • Engage the IPA for independent assurance / recommendations
Maintaining the PERSONNEL necessary for the Programme.	<ul style="list-style-type: none"> • 90 day roadmap of personnel / professional services support requirements • Status report on fulfilment of personnel / professional services support requirements • Secondment / recruitment process compliance • HR policy compliance • HR risks / issues • Issues / risks raised by the PSG, IPA, Programme participants regarding personnel 	<ul style="list-style-type: none"> • Approve / reduce headcount for recruitment / secondment • Intervention for non-compliance with HR policies • Intervention for professional services support • Intervention for HR issues / risks • Engage the IPA for independent assurance / recommendations
Maintaining the IT SYSTEMS AND FACILITIES necessary for the Programme.	<ul style="list-style-type: none"> • 90 day roadmap of IT & facilities requirements • Status report on fulfilment of IT & facilities requirements • Procurement process compliance • Legal review of contracts • Risks / issues regarding contract disputes / changes • Issues / risks raised by the PSG, IPA, Programme participants regarding IT systems and facilities 	<ul style="list-style-type: none"> • Start / terminate procurement processes • Ratify / reject procurement decisions • Sign procurement contracts • Ratify contract changes / cancellations • Intervention for non-compliance with procurement policy

<p>Monitoring and managing the PERFORMANCE of the MHHS Programme Implementation Manager roles.</p>	<ul style="list-style-type: none"> • Performance objectives per role • Status report of performance against objectives • Issues / risks raised by the PSG, IPA, Programme participants regarding role performance • Issues / risks raised by Ofgem • Information to support performance assessments and intervention • Information relating to the status of the MHHS Programme (milestones, objectives, KPIs) • Information on risks, issues and mitigations 	<ul style="list-style-type: none"> • Engage the IPA for independent assurance / recommendations • Define / approve / modify performance objectives • Implement remedial actions to address under performance • Replace personnel / service providers • Reallocate personnel • Engage the IPA for independent assurance / recommendations • Engagement with Ofgem • Escalation of issues
<p>Ensuring that MHHS IM resources and infrastructure are sufficiently SEPARATED from those used as a participant.</p>	<ul style="list-style-type: none"> • Evidence of Separation governance, controls and compliance • Issues / risks raised by the PSG, IPA, Programme participants regarding conflict of interest. • Changes to MHHS Governance Framework 	<ul style="list-style-type: none"> • Propose to Ofgem amendments to the Business Separation Plan • Implement remedial actions to address conflict of interest risks / issues • Engage the IPA for independent assurance / recommendations
<p>Ensuring an ACCOUNT is kept of costs, expenses and liabilities incurred in the role of MHHS IM.*</p>	<ul style="list-style-type: none"> • Budget • Forecast • Actual • Exceptions • Finance policy compliance • Finance risks / issues 	<ul style="list-style-type: none"> • Approve the annual budget as per BSC modification P423. • Approve the collection of funds from Parties • Engage the IPA for independent assurance / recommendations

*Note: The Exelon Finance Director will have access to the MHHS Programme finance information to ensure finance controls are maintained and to proactively manage Exelon cash-flow.

10.7 Outsourcing majority of programme roles

The majority of the MHHS Programme roles and resource requirements will be outsourced to a Lead Delivery Partner. ~~Exelon has undertaken a competitive procurement process and is in the final stages of awarding the contract.~~ The roles that require industry expertise, such as SRO and DA, will be resourced with a combination of [the Exelon MHHS Programme Executive Representative](#), Exelon secondees, Exelon fixed-term employees recruited for the MHHS Programme, industry secondees and consultants for specific deliverables.

MHHS Role	Resourcing
SRO	As delegated by Exelon

DA	As delegated by Elexon
PMO	Lead delivery partner
PPC	Lead delivery partner
SI	Lead delivery partner

10.8 Recruited external resources

The MHHS Programme has recruited external resources to support the following roles during mobilisation:

- Procurement
- Governance
- Communications & Stakeholder Management
- Separation
- Design
- PMO

10.9 Forecasting support services requirements and monitoring performance

The SRO will offer a quarterly roadmap of programme resources and professional service requirements to the Elexon [Board \(or any Board committee to which it has delegated oversight of the MHHS Programme ~~Executive Sponsor~~\)](#) and a monthly RAG report on the performance of programme resources, service providers and Elexon professional services support.

10.10 Professional services support

Elexon is providing professional services support while the Programme is mobilising. It is envisaged that Elexon will continue to provide support for specific functions throughout the Programme duration, such as HR and Legal. The longer term solution for professional services support will be assessed when the LDP is appointed.

Where professional services support is provided by Elexon it will not be exclusively for the MHHS Programme as certain services, such as HR and Legal, would not be fully utilised, the conflict of interest risk is low and it would not be economical and efficient. Should the need arise to provide professional services support exclusively to the MHHS Programme then it will be considered by the Elexon MHHS Programme Executive [Sponsor Representative](#). The MHHS Programme will make an appropriate cost recovery contribution in respect of the professional services support it receives, as explained in section 10.11.

Professional service	Type of support
HR	Recruitment & on-boarding support. General HR and performance management support.
Finance	MHHS budget and reporting. Monthly Elexon recharge billing.
Legal	Legal support
Procurement	Guidance on adherence to Elexon procurement policies

IT	Hardware and software as requested by SRO. IT incident and service request support.
Facilities	Facilities and support as requested by the SRO

10.11 Recharging Elexon costs

The recharging of costs will follow the existing recharge processes used for the Contract for Difference and Capacity Market settlement services, which Elexon has been operating for many years. Elexon includes within those charges, a standard overhead cost per employee / fixed-term contractor to recover occupancy, office and corporate overheads. For services and resources that are only used part-time, an hourly rate is calculated. Contributions recovered in this way for overheads are used to defray existing overhead costs for BSC business as usual activities as those overheads are now being spread over other activities/personnel.

Type of cost	Description	Recharge
Full-time resource	Elexon secondees and fixed-term employees recruited to work on the Programme full time.	The full cost of the resource and overhead charge is recharged to the MHHS Programme.
Professional services support / part-time resources	Professional services support (e.g. IT, HR, finance) and part-time resources (e.g. Angela Lovethe Elexon MHHS Programme Executive Representative).	The hourly cost of the resource, including overheads, is recharged to the MHHS Programme.
Programme specific expenses	Service providers and specific expenses such as specific IT hardware.	The full cost is recharged to the MHHS Programme.

11. Cultural separation

This section explains Elexon's solution to the cultural separation obligations as per the Business Separation obligations defined in the MHHS Governance Framework.

Elexon believes that it is creating a unique culture for the MHHS Programme by giving the Programme its own identity and physical presence; and recruiting the best skills and companies to resource the Programme, whilst also seconding Elexon and industry stakeholders to guide the solution design. All Implementation Manager roles will be resourced by fixed term contractors and the Lead Delivery Partner (as explained in section 10.7 and 10.8) except where Balancing and Settlement subject matter expertise is required.

Elexon has already begun educating its employees of the potential for conflict of interest and the need for Business Separation, as illustrated by the CEO's communications in Appendix 5.

For the few Elexon employees and fixed term contractors recruited for the Programme, clear HR, communication and engagement principles have been defined, and will be communicated via awareness training.

Elexon believes the Business Separation Plan will support the development of an autonomous and high performing culture within the Programme, whilst allowing Elexon secondees to continue to remain a part of the Elexon family.

Rather than isolate Elexon secondees from Elexon (some who have been employed by Elexon for 20 years), the approach has been taken to advise and educate all Elexon employees (seconded and not seconded) of the potential

conflict risk and what is permitted / not permitted. In addition, seconded employees and new starters will agree to abide by the separation guidelines (11.5).

11.1 Conflict-of-interest awareness training

An awareness training program will be designed and operated to help Elexon employees and MHHS Programme management resources to understand the conflict-of-interest risks and the role they play in helping to identify and mitigate the risks. The training content and records of attendance will be shared with the IPA.

11.2 Seconding Elexon Subject Matter Experts (SME) and recruiting fixed-term employees

Work is underway to identify all the skills needed in the Programme and what expertise Elexon can provide to bolster the Programme. Elexon has begun seconding employees with subject matter expertise and recruiting fixed-term employees for the MHHS Programme, this will be further informed by the procurement of the LDP and in consideration of how the MHHS IM roles will be managed.

All Elexon employees who join the MHHS Programme will not work on the Elexon Central Systems internal programme for MHHS (Project Helix). Their responsibilities, line management, performance objectives and decision making abilities will be formally modified to those required by the MHHS Programme. Some of the secondees are important sources of corporate memory and knowledge and may be consulted from time to time on other Elexon BAU issues.

11.3 Elexon HR principles

The following principles have been agreed with Elexon HR, with respect to existing Elexon employees who are seconded to the MHHS Programme, and new employees recruited for the MHHS Programme.

- Secondees will receive and sign a secondment letter which will document the terms of their secondment.
- The secondment period may vary between employees and will be based on need.
- There is no change to the employment contract or benefits of secondees, unless the Elexon MHHS Programme Executive [Sponsor/Representative](#) justifies a change (such as an increase in remuneration), which will only apply for the period of secondment.
- Secondees and new employees will receive Elexon company news and information, and corporate learning, training and self-development.
- Secondees will maintain access to their Elexon email account (to provide access to legacy emails and information). Secondees and new employees will only communicate using their “MHHSProgramme.co.uk” email addresses.
- Secondees and new employees will have performance objectives and incentives that are aligned with the MHHS Programme.
- Secondees will report to an Elexon permanent employee / fixed-term employee that is seconded to the MHHS Programme.
- At the end of the secondment the secondee will return to their substantive post or an equivalent role (if this is not possible) on terms and conditions no less favourable than current terms and conditions of employment.
- Upon leaving the MHHS Programme, secondees may not discuss or share MHHS Programme information, and will no longer have access to the MHHS Programme email addresses or data.
- Should the secondee seek to end their secondment early, a notice period will be agreed upon with the Elexon MHHS Programme Executive [Sponsor/Representative](#).
- Should the secondment period need to be extended, the extension must be approved by the Elexon MHHS Programme Executive [Sponsor/Representative](#).
- Should the need for the secondment dissipate, the secondee will be given as much notice as possible before leaving their MHHS Programme role.

- Secondees and new employees are permitted to apply for vacancies or promotions.
- Should a secondee or new employee resign, their contractual notice period will apply.
- Secondees and new employees recruited for the MHHS Programme will be required to comply with all Elexon policies, undergo conflict of interest awareness training and sign an acknowledgement that they have been informed of, and will comply with the Business Separation Plan.

11.4 Employee communications

A communications strategy and plan has been developed for internal and external stakeholders. The internal communications were initiated in July, with Mark Bygraves (CEO) explaining Elexon’s MHHS Separation obligations to all Elexon employees at the July 2021 companywide Webtalk and regular communications are scheduled to be delivered via newsletters, webinars and email.

Appendix 5 provides a copy of the CEO communications in the July 2021 companywide Webtalk.

11.5 Elexon engagement guidance

The efficient delivery of a programme of this nature depends on collaboration and communication. Subject to the guidelines below, there is no intent to restrict ad-hoc conversations between parties to resolve / clarify issues. However, to ensure transparency and to mitigate the conflict of interest risk, there will be a requirement for working groups to acknowledge and record the Elexon teams that can be consulted during the development of specific programme artefacts.

For example, “The design working group acknowledges that members of the MHHS design team can engage with members of the Elexon XYZ team in relation to the development of design artefacts A, B and C”.

The following guidelines will be communicated to MHHS Programme members.

MHHS Programme members SHOULD	MHHS Programme members SHOULD NOT
Maintain friendships and relationships with Elexon colleagues.	Share MHHS Programme information with Elexon colleagues outside of formal programme communication channels. (Example communication channels are working groups, PPC, PMO)
Attend Elexon events and news briefings.	Give preference to Elexon when making decisions that affect other participants (e.g. prioritizing Elexon activities over those of other participants)
Continue to collaborate (the Programme needs everyone’s expertise for success).	

12. Physical separation solution

As per the Business Separation obligations in the MHHS Governance Framework, Elexon must ensure its role as MHHS IM is kept physically separate from its role as an MHHS participant by means of separate office spaces, websites, and email addresses.

12.1 MHHS brand

A brand and corporate identity has been developed for the MHHS Programme and will be used on all digital and print media, and all programme correspondence. The tag line, "Industry-led, Elexon facilitated", has been included in the full MHHS logo to acknowledge the industry's control of the Programme and Elexon's role.

Appendix 6 provides an example of the MHHS Programme logo.

12.2 MHHS email addresses

The following domains have been acquired: MHHSProgramme.com / .co.uk / org.

All Programme resources, including secondees, new Programme members and the LDP, will use the MHHS Programme email address. The Programme team members who initially did have Elexon e-mail accounts have now been migrated to the MHHS email domain and no longer use the Elexon domain for communication, but retain access to their Elexon email account for access legacy emails and information.

The email accounts will be hosted in the Elexon environment in the short term and the longer term solution will be determined through consideration of the LDP contract.

Appendix 7 provides an example of the MHHS Programme email addresses.

12.3 MHHS office space

Accommodation requirements are being assessed during the current mobilisation phase. As an interim measure a conference room has been secured exclusively for the MHHS Programme in the Elexon building on 350 Euston Road. The room can accommodate 12 people and is dedicated to the MHHS Programme. Elexon operate a clear desk policy for all their offices and no documents are left on office desks.

Appendix 8 provides a picture of the dedicated MHHS Programme office space.

12.4 MHHS website

The MHHS website is accessible via the MHHSProgramme.com/ .co.uk/ org domains, with the co.uk domain being the primary domain. The website is live, MHHS branded, hosted independently and maintained by the MHHS Programme.

The website will be the central intelligence hub for all MHHS stakeholders and will be continuously developed according to the intelligence requirements of each phase of the Programme. Key MHHS staff and their roles in the Programme will be listed on the website and any communications from the Programme will have key contact details contained every time they are issued.

Appendix 9 provides an image of the MHHS website holding page.

12.5 Programme exclusive data directory

An exclusive directory for the Programme has been created on the Elexon File Server and access is restricted to the MHHS Programme team and Elexon IT. The long term data storage solution will be determined through consideration of the LDP contract.

13. Implementation and maintenance

~~The Exelon MHHS Programme Executive Sponsor is the owner of the Business Separation Plan and will be responsible for implementing and maintaining the Business Separation Plan.~~ The Exelon Board has delegated the responsibility [for the Business Separation Plan](#) to the Exelon MHHS Programme Executive ~~Sponsor~~[Representative](#), but they remain ultimately accountable.

The Exelon MHHS Programme Executive ~~Sponsor~~[Representative](#) shall:

- Ensure the Business Separation Plan is implemented and maintained.
- Ensure there is regular reporting to the Exelon Board and IPA on the implementation and ongoing effectiveness of the Business Separation Plan.
- Ensure the Business Separation Plan is kept up-to-date with mitigating controls for potential conflict of interest risks and in changes with Exelon's strategy and any future roles Exelon may take up.
- Ensure the Business Separation Plan is kept up-to-date with changes to the Programme landscape, such as:
 - Changes to Programme governance,
 - Changes to personnel fulfilling the SRO and Exelon MHHS Programme Executive ~~Sponsor~~[Representative](#) roles,
 - Assessing and acting upon IPA and Ofgem recommendations.
- Ensure risks and issues relating to the potential conflict of interest are identified, managed and addressed in a timely manner.
- Ensure the Exelon Board and IPA is informed of material risks and issues (high impact and high probability) of a conflict of interest in Exelon's role as the MHHS IM and MHHS Programme participant.

Appendix 1

Summary of industry responses to Ofgem consultation, regarding conflict of interest.

Reference: Consultation document - Implementation Arrangements for Market-Wide Half-Hourly Settlement

“2.9. There was strong agreement from respondents on the existence of a potential risk to implementation through a possible conflict of interest in Elexon being appointed as Senior Responsible Owner (SRO) for the programme. In particular, carrying out the Programme Management Office (PMO) and design authority functions, as well as having a central role in building the systems needed to deliver MHHS.

2.10. Additional to the risk of conflict of interest in carrying out the SRO role, a few respondents suggested a further potential risk in this area arises through Elexon appointing and contracting with the independent assurance function which will provide assurance on the governance processes and programme decision making.

2.11. A further concern was raised over the potential for Elexon bias towards BSC parties given that the existing BSC governance does not equally represent all facets of the industry. These respondents felt that Elexon’s default position will be to favour the interests of BSC parties, whom they essentially view as their customers. This view was echoed in the independent assessment report by Complete Strategy.

2.12. Finally, there were strong views amongst stakeholders that there should be a visible and tangible separation of Elexon’s programme management function from other parts of Elexon’s work. One of the recommendations in the independent assurance assessment [Complete Strategy] report was to ensure explicit and visible physical, organisational and cultural separation of the programme management function from other parts of Elexon’s work.”

Appendix 2

Examples of potential conflict of interest as highlighted by Ofgem

Reference: MHHS Governance Framework

“1.24 ... Elexon itself, in its role as MHHS IM is not giving any preference to Elexon in its role as BSC system provider, for example, testing, defect triage, the resolution of defects and issues, change impact assessments, the provision of Integration services and environments, etc.”

Reference: OFGEM response (Rachel Clark), 26 May OFGEM meeting

“The [Elexon] Board should not be taking (or seeking to influence other than through Programme governance as the BSC system provider):

- decisions on design that impact parties other than Elexon;
- decisions relating to flows of, or access to, data;
- decisions on timing of implementation that have any impact on parties other than Elexon;
- decisions on the operation of programme governance, including the scheduling of testing, provision of environments, prioritisation of defects etc.”

Appendix 3

Accountability matrix, illustrating MHHS accountabilities agreed between Ofgem and Elexon.

	Sponsor: OFGEM	IM: SRO	IM: GENERAL
Timelines	Defines and controls milestone baseline. Takes decisions on 'above threshold' changes to milestones	Manages delivery according to Ofgem approved milestone baselines. Takes decisions on 'below threshold' milestone changes.	
Cost	Where the budget baseline changes by an amount that exceeds the level 1 threshold, then Ofgem, as the sponsor, will be the decision maker.	Manages budget according to budget baseline. Takes decisions on 'below threshold' budget changes.	Records cost, expenses and liabilities.
Outcomes / benefits	Defines business case and expected outcomes baseline. Takes decisions on changes to business case and expected outcomes.	Reports on outcome realisation.	
Governance	Defines governance framework. Takes decisions on material changes to the governance framework.	Manages governance compliance. Manages the change control process.	Manages separation compliance.
Programme resources & infrastructure	Secures IPA, manages IPA performance, manages IPA contract.	Manages day to day activity. Forecasts resource and infrastructure requirements (excl IPA). Reports on resource and infrastructure performance (excl IPA).	For all programme resources excluding IPA: Secures and maintains resources, service providers and infrastructure according to scope. Manages performance of programme resources, service providers, infrastructure. Negotiates with service providers, manages contracts. Manages Elexon conflict of interest risk (separation).
Information		Manages information gathering, storing, analysis & distribution.	Manages Elexon conflict of interest risk (separation).
Solution	Defines TOM baseline (incl post AWG arch) Takes decisions on 'above threshold' changes to TOM.	Manages TOM development and code change proposals. Manages alignment of the implementation of system and process changes across participants. Manages testing and readiness.	
Industry participants	In unlikely scenario will enforce action (licence breach).	Manages participant collaboration. Reports on participant performance.	
External dependencies	Manages external dependencies (other industry initiatives external to MHHS programme)	Highlights external dependencies	
Decision making	Decisions are made by Ofgem	The SRO will make decisions in PSG, informed by PSG and seeking consensus among PSG members. Where the SRO is unable to achieve consensus they will articulate the reason for their decision, and the dissenting voices, and seek the views of the independent assurance provider, and Ofgem.	Material decisions are made by the Elexon Board. The Elexon Board can consult with Ofgem, IPA and PSG.
Conflict of interest risk		When a SRO decision is influenced by an Elexon representative (Board / Exec / Employee) outside of the PSG.	When programme resources or infrastructure are negatively effected by Elexon demands/capacity/decision making.

Appendix 4

Ofgem decision-making thresholds.

Reference: MHHS Governance Framework

“1.57 Without limiting the circumstances in which Ofgem may choose to take particular decisions and direct particular courses of action, Elexon (as SRO), with the agreement of the IPA, will ensure that the following are referred to Ofgem for determination:

- any forecast or re-plan that would move one or more of the level 1 milestones by 3 months or more;
- any decisions that would require a material or fundamental change to the Target Operating Model. A material or fundamental change would include:
 - a change that materially changes the TOM services (for example a change for what they are responsible for, or who can carry them out);
 - a change to any of the policy decisions made on access to data or agent functions;
 - a creation of business process Service Level Agreements (SLAs) that would impact the reduced settlement timetable;
 - a change which means the TOM would no longer meet the TOM Design or TOM Development Principles; and/or
 - a change to the settlement timetable.
- any decisions that would alter the forecast costs or benefits of MHHS compared to those set out in Ofgem's impact assessment published on 20 April 2021 for MHHS by more than: £5m for an individual decision, or £20m cumulatively;
- any decisions that could have a significant impact on competition or market stability, including where a situation arises in which a party or parties argue that their interests are being treated less favourably, without good reason, than those of other parties;
- any decision that could have a significant impact on consumers; and/or
- any significant changes to this governance framework, including where changes are proposed to the scope of the IPA's remit or to the criteria or thresholds for Ofgem intervention.

1.58. For clarity regarding the first bullet above, once a change to (for example) a level 1 milestone is agreed by Ofgem then the plan would be re-baselined on that basis and any subsequent movement of a level 1 milestone by 3 months or more from that plan would again require Ofgem approval.”

Appendix 5

A copy of the CEO communications by CEO Mark Bygraves in the July 2021 companywide webtalk.

-Start-

Last month, Angela gave an update on the different workstreams in the programme. One of those workstreams is the separation workstream which aims to address industry concerns regarding the potential conflict of interest between our work leading the programme and the changes we will need to make to our BSC central systems as a market participant in the programme. We have been looking at what that actually means for us and the people working on the programme.

To begin with, and most importantly, our Elexon colleagues seconded to the programme are still Elexon employees and still part of the Elexon family. They have just been seconded across to work on the MHSS programme for the duration. You can still speak to all your colleagues, they will still be able to attend these web talks, be invited to the tea and talks and attend any social activities. I know there has been some chat that such things wouldn't be permitted but that's not the case.

However, when it comes to information on the MHHS Programme, this must only be shared through formal channels, such as working groups, to ensure fair treatment of all programme participants. Similarly, all programme delivery decisions, such as prioritisation and scheduling, will be decided at the Programme Steering Group, which will incorporate industry representatives. I think at one point we thought those on the programme would need to sign a Confidentiality Agreement or Non-Disclosure Agreement, but we've concluded this is unnecessary and OTT. Having said that those involved will receive guidance on how to prevent a conflict of interest.

As this is an industry led programme, it needs its own identity and we have recently developed a brand for the programme, and will soon launch its own website. You will also begin to notice that those working on the programme are using MHHSProgramme.co.uk email addresses.

Until the formal separation happens, which is when Ofgem formally hands over the SRO function to Elexon, potentially around October, the programme will be working with colleagues across Elexon to ensure that we have the resources and are set up for success. This will mean that some people will need to work on MHHS Programme activities and on BSC activities. The Design workstream is a good example of this whereby the CCDG and AWG work needs to continue to evolve even though some of you are starting to work on the projects connected to the BSC Central Systems Development programme.

If you're interested in getting involved in the programme, and especially the Design workstream, then please let Angela or Chris Welby know. Clearly we will need to recruit a number of roles and the process will result in a mix of existing Elexon colleagues being seconded and new joiners.

-End-

Appendix 6

An example of the MHHS Programme brand.

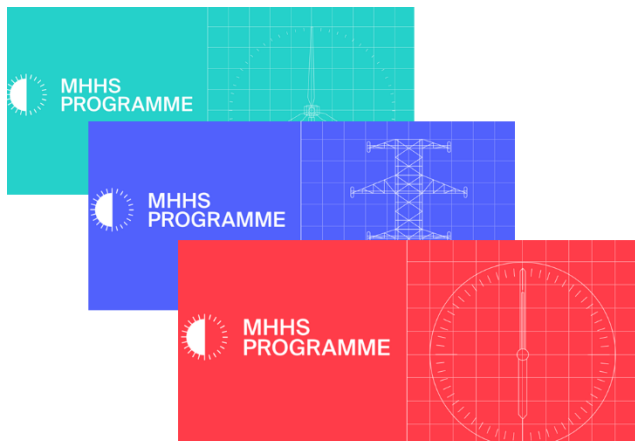

An example of the MHHS Programme logo (includes “MHHS PROGRAMME” and “Industry-led, Elexon facilitated”).



Appendix 7

An example of the MHHS Programme email addresses.



Charles Hyde

MHHS Procurement Lead

Direct line: 020 7380 4194

Email: Charles.Hyde@mhhsprogramme.co.uk

Implementation Programme

Market-wide Half Hourly Settlement

4th Floor, 350 Euston Road

London NW1 3AW

www.mhhsprogramme.co.uk

Appendix 8

The dedicated MHHS Programme office space.



Appendix 9

The MHHS website and domain.

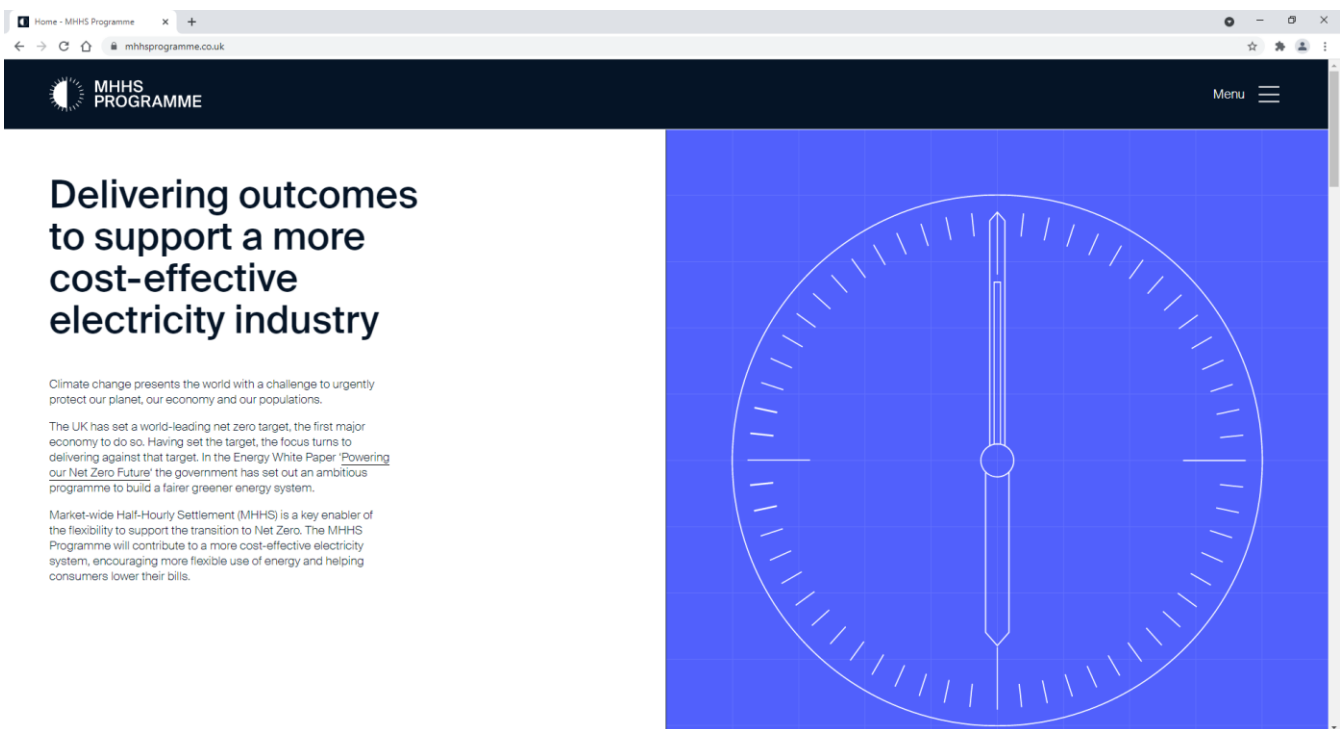

Appendix 10

Business separation obligations

Reference: MHHS Governance Framework

“1.8. It is important that Elexon's role as MHHS Implementation Manager is kept separate from its role as an MHHS Participant.

1.9. Elexon shall develop, obtain Ofgem's approval of, and comply with a business separation plan which requires explicit, physical, organisation and cultural separation, including:

- Physical – separate office spaces, websites, and email addresses.
- Organisation – the people who are taking operational and management decisions in relation to the MHHS Implementation Manager roles must not be the same people who take decisions in relation to the MHHS Participant role. Reporting from the MHHS Implementation Manager units to the Elexon executive and board should be in accordance with BSC Section C 12.4.3.
- Cultural – this may be achieved through appointment of external service providers for particular roles, but can also be achieved through staff training on awareness of separate functions.

1.10. Amongst other things, the MHHS Independent Assurance Provider will be responsible for identifying and reporting on issues relating to business separation and Elexon's conflicts of interest. Where the assurance provider considers the issues are material, they will bring them to Ofgem for consideration. Ofgem will then be able to make directions concerning any issues identified, which may include directing Elexon to amend its business separation plan (noting the Elexon is required under the BSC to comply with Ofgem's directions concerning implementation).”

Appendix 11

Elxon Board MHHS oversight remit, access to information and the IPA

Reference: BSC, Section C12.4.3, which came into effect on 7 October 2021.

“BSCCo shall ensure that the service providers, personnel, IT Systems and facilities it uses to perform its role as MHHS Implementation Manager are sufficiently separated from those it uses as an MHHS Participant, as further described and set out in the MHHS Governance Framework and a business separation plan to be approved by the Authority.

The Board shall ensure that BSCCo complies with this paragraph 12.4.3. Without limitation, the Board shall maintain appropriate delegations to specified executive members and the MHHS SRO (and, by extension, the rest of the MHHS Implementation Manager function).

BSCCo shall ensure that, where it does need to share any MHHS Implementation Manager information with its executive or board members to facilitate the performance of their oversight responsibilities, such information is anonymised between MHHS Participants.

BSCCo shall also ensure that the Authority and the MHHS Independent Assurance Provider are informed that the information has been shared and provided with a record of any decisions in relation to it. Subject to such oversight, and notwithstanding programme information available to MHHS Participants, information available to the MHHS Implementation Manager roles must not be shared with the rest of BSCCo (including the Board).

Subject to compliance with the MHHS Governance Framework the Board shall be entitled to meet with the MHHS Independent Assurance Provider and to ask the MHHS Independent Assurance Provider to consider and report on any matter in relation to performance of the MHHS Implementation Manager roles (in which case such reports shall be made available to all MHHS Participants, unless the Authority directs otherwise).”